

CONTA BIN BLENDER :



Ideal equipment for blending within a closed environment and dust free operation. The Quality of the blending is achieved by the shape of the container without any internal baffles. The unit is most suitable for handling of different size containers by using a common drive.

Salient Features :

- 0° stopping for easy docking and undocking of the bin
- Safety guard around the blender bin
- Proximity Sensor is provided for safe operation
- Flexibility of accepting variable bin sizes in single drive unit.
- cGMP Construction
- S.S. 316 Butterfly valve at the bottom suitable for discharge.
- Vent nozzle on top Most effective for low volume active ingredient blending with as low as 1 to 1.5%

Technical Data

Capacity in Ltrs		150	300	600	1000	1200	1500
Motor	HP	2	2	4	6	6	10
Dimensions in mm	A	2500	2550	2650	3200	3350	3550
	B	2500	2575	2750	3400	3550	3700
	C	2000	280	2400	3000	3880	3950

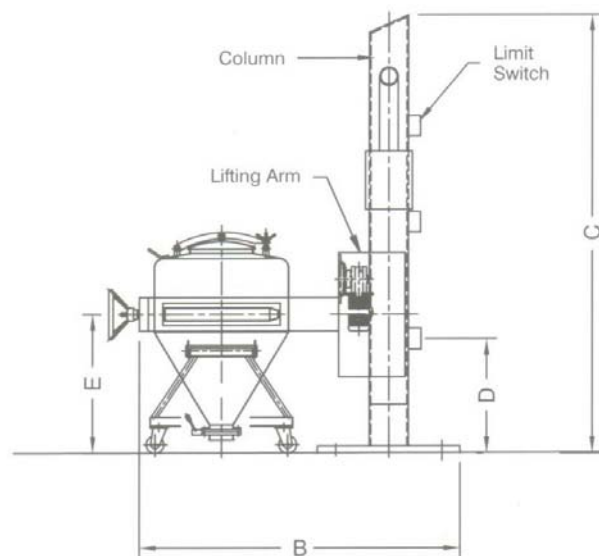
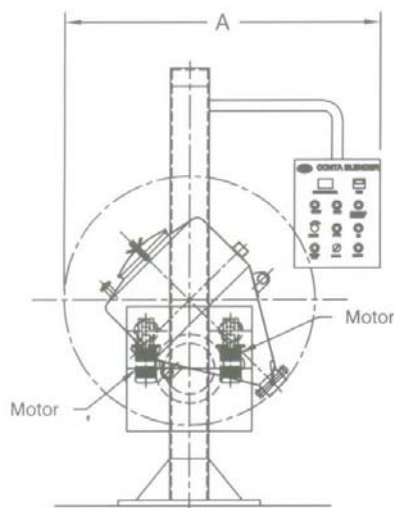

Note : Images Shown here are illustrative. As the design & manufacturing of Machines are subject to improvement, the product supplied will be as per our Techno-Commercial offer.